

510.01

BRITISH
HAND
&
RIFLE
GRENADES

INTRODUCTION

British armed forces use anti-personnel of both the "offensive" and "defensive" types. The standard defensive grenade is of the time delay type while the No. 247 impact fuze is used in the E.F. offensive, White Phosphorus, and Smoke Grenades. The fuze mechanism which initiates the British time delay grenades is no more or less a disposal problem than the similar U. S. device. However, the impact fuze requires careful consideration as a delicate disposal item. They are most likely to be found armed and when so are very sensitive.

A large number of rifle grenades became obsolete early in this war. Rifle grenades are dropping more and more from the picture. The British P.I.A.T. anti-tank weapon, a counterpart of the American bazooka, has largely replaced the anti-tank rifle grenade.

The grenades included in this publication are thought to be those which will be found in the field. It should be complete in that respect.

TABLE OF CONTENTS

36 M Anti-Personnel Rifle Hand Grenade	Page 137
No. 69 Mk I Anti-Personnel Hand Grenade	139
No. 82 Anti-Personnel Grenade (Jamson Bomb)	141
No. 77 (WP) Smoke Grenade	143
No. 80 Mk I (WP) Smoke Grenade	145
No. 78 Mk I Smoke Grenade	147
No. 83 Mk I Colored Smoke Grenade	149
1-1/4 lb. Incendiary Bomb Mk I	151
No. 63 Anti-Tank Grenade	153
No. 74 Mk II Anti-Tank S.T. Grenade	155
No. 75 Anti-Tank, "Hawkins", Grenade	157

BRITISH

SCREW PLUG IN
FILLING HOLE

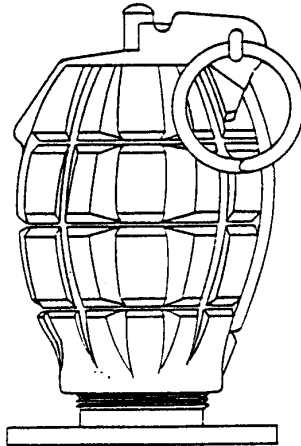
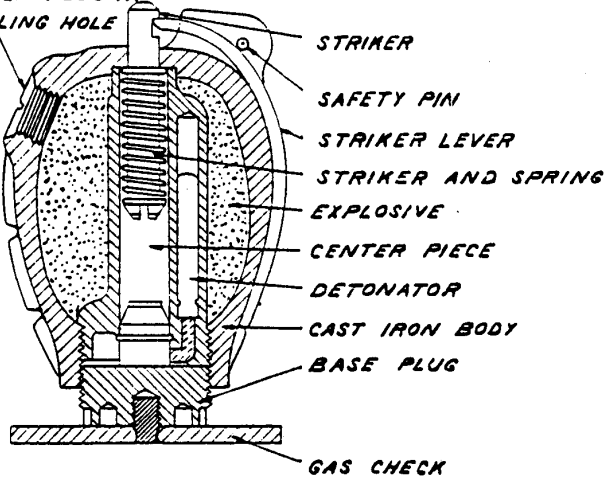

**36M ANTI-
PERSONNEL
RIFLE HAND
GRENADE**

RESTRICTED

Data

Overall length . . . 4 in.
Maximum diameter . . . 2.4 in.
Color Black.
Markings Green band around center. Red band or crosses around top. Crosses denote that filling is all right for storage in tropical climate.
Total weight 1-1/2 lbs.
Filling Standard, Baratol
Delay 4 and 7 seconds.

Description

This grenade consists of a lemon shaped cast iron body filled with high explosive. The body has three holes in it, one in the base for priming, one near the top for filling, and one in the top through which the striker protrudes. The body is serrated and rather thick so as to give good fragmentation. Through the middle of the body is a center piece containing a striker and spring, a primer delay train, and detonator.

The striker is held up and the striker spring is held cocked by a lever which fits into a slot in the top of the striker. The lever is secured by a safety pin passing over it and through holes in two shoulders which project on the outside of the body. The lever is shaped with two small projections which fit into notches in these shoulders to provide a pivot. The lever projects down the side of the grenade body, matching the body contour. The filling hole is closed by a screw plug. The base plug threads into the base opening and is itself threaded to receive a 2.5" diameter metal gas check disc for use when the grenade is fired from the rifle projector.

The igniter consists of a .22 cal. cap in a cap chamber, a short length of safety fuse, and a detonator. There are two types of igniters. One is white, has a rubber band on it, and has a 4-second delay. This is used when the grenade is to be thrown. The other is colored yellow, lacks the rubber band, and has a 7-second delay. This is used when the grenade is fired from the discharger.

Operation

Priming consists of removing the base plug, inserting the detonator and the cap chamber into their respective sleeves, and replacing the base plug.

When the grenade is to be thrown it is held with the throwing hand over the safety lever and the safety pin is removed with the other hand. When the grenade is thrown, the lever is released as the hand releases the grenade. The striker spring forces the striker downward, rotating the lever about its pivot and throwing it off. The striker hits the cap which sets off the delay which sets off the detonator which explodes the grenade.

If the grenade is to be fired from the discharger it must be primed with the 7-second igniter and the gas check disc must be threaded tightly on to the base plug. The grenade is placed in the discharger, base first. When the grenade is down inside the discharger so that the lever is held by the sides of the discharger, the safety pin is removed. When the grenade is fired and leaves the discharger, the safety lever is no longer held and flies off allowing the striker to hit the cap. Latest available information is that the grenade is not used as a rifle grenade however.

**BRITISH
36M ANTI-
PERSONNEL
RIFLE HAND
GRENADE**

BRITISH

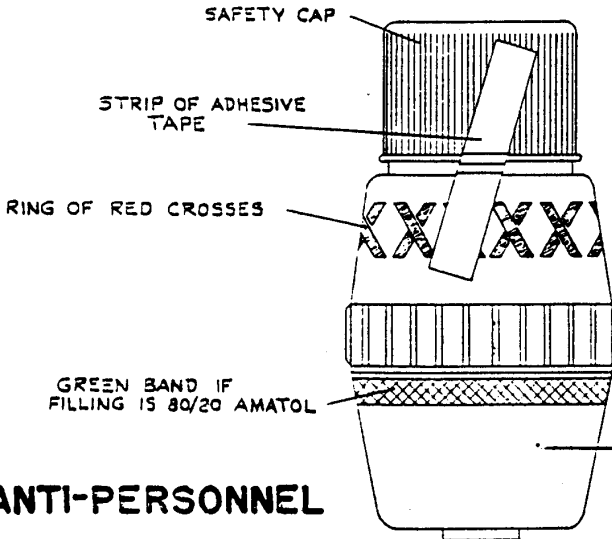
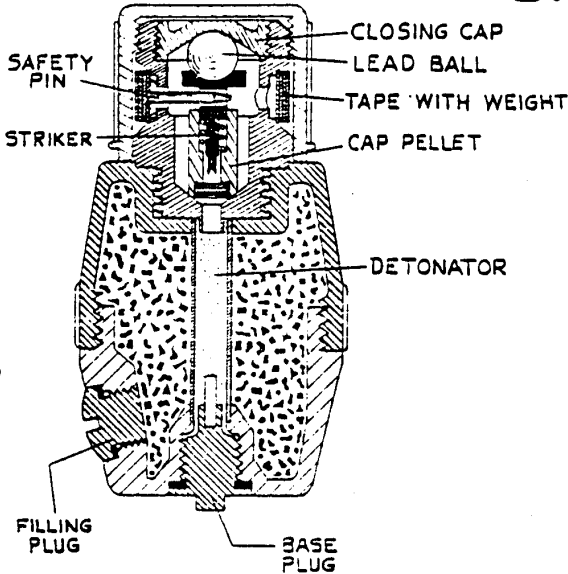

ANTI-PERSONNEL HAND GRENADE

NO. 69 MK. I

R E S T R I C T E D

Data

Overall length . . . 5-1/2 in.
Maximum diameter . . . 2-3/8 in.
Color Black.
Markings As on drawing.
Total weight 11 oz.
Filling Amatol 80/20 or
Lyddite.
Fuze No. 247 Mk 1.

BRITISH
ANTI-
PERSONNEL
HAND GRENADE
NO. 69 MK. I

Description

This grenade is a light, impact firing grenade for offensive action. The body is made of bakelite. The area of burst is very limited and it can, therefore, be thrown standing in the open. The two piece body threads together in the middle. There is a filling hole and plug and a priming hole and plug in the base section. The bakelite holder for the fuze threads into a large indentation in the top section. There is a detonator well running lengthwise through the filling. The fuze is all-ways acting. The striker rests on a creep spring inside a striker sleeve. There is a hole in the base of the sleeve through which the striker protrudes when the spring is compressed. The striker head is cut to receive a lead ball. The closing cap is shaped so that a convex surface fits over the ball. A safety pin passes through a hole in the fuze holder and beneath the striker head to rest on the top of the striker sleeve. A length of tape is attached to this pin. The tape winds around the striker holder and has a small lead weight on its free end. A light bakelite cap threads over this whole assembly. This cap is held securely by a piece of adhesive tape.

Operation

The detonator is inserted, open end first, into the base hole and the base plug is replaced. The adhesive tape is then removed and the safety cap unscrewed in 1/2 of a turn. After the cap is removed the tape must be held in place by the forefinger and thumb. When thrown, the weight on the end of the tape causes the tape to unwind and pull out the safety pin. Only the creep spring is now holding the striker away from the primer cap. On impact the striker is forced into the primer cap, igniting the delay which initiates the detonator and explodes the grenade.

Remarks

Once the tape has unwound and the pin has come out from the striker, the grenade is in a very sensitive condition and should be destroyed in situ. If for some reason this is impossible, and it is essential that the grenade be moved, use should be made of long handled tongs or some similar implement, and the operator given the best improvised protection possible.

BRITISH

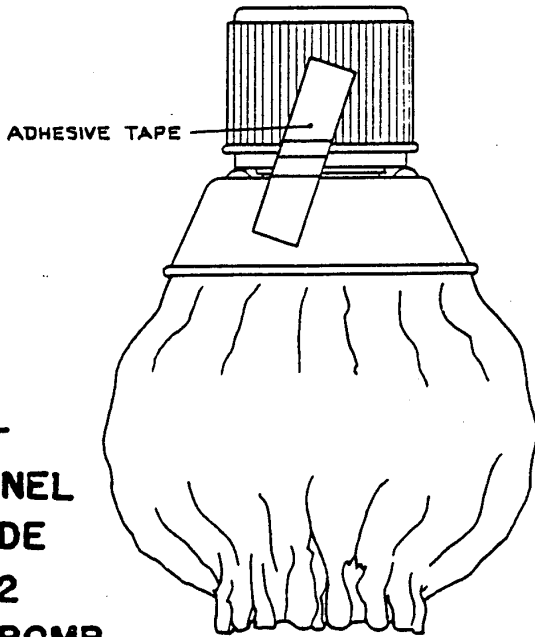
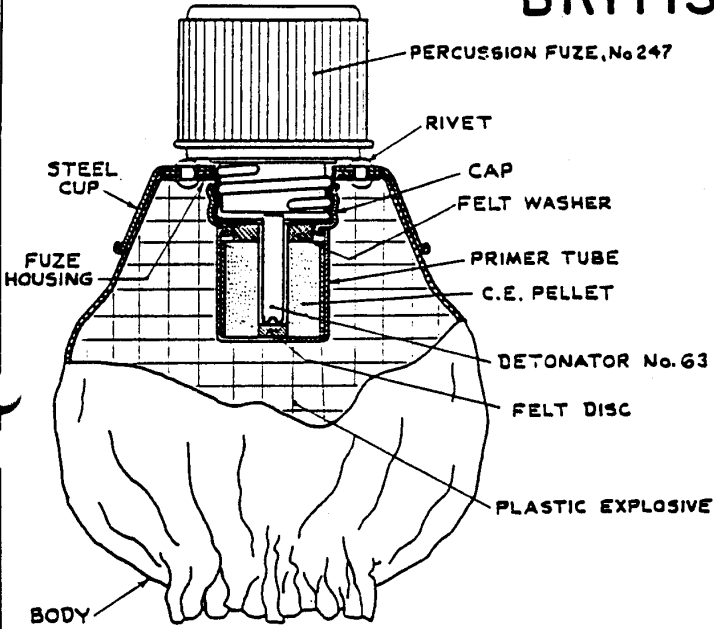

**ANTI-
PERSONNEL
GRENADE
NO. 82
GAMMON BOMB**

110 R E S T R I C T E D

BRITISH

ANTI- PERSONNEL GRENADE NO. 82 GAMMON BOMB

Data

Color Fuze, black; cup,
buff; bag, black.
Markings See drawing.
Fuze No. 247 Modified.
Filling Plastic explosive.

Description

The body of this H.E. all-ways grenade, formerly known as the Gammon Bomb, consists of a fabric bag, open at each end. The lower end of the bag is gathered in and an elastic band inserted around the edge, while the upper end fits under a steel cup, the edge being clamped between the cup and the flange of a tinne plate housing for the fuze by 4 equally spaced rivets. A tin plate cap, to the lower end of which is secured an aluminum primer tube, is screwed over the fuze housing.

The grenade is fuzed with the No. 247 percussion fuze wound with $4\frac{1}{2}$ " of tape instead of the usual 12", and the primer tube contains a C.E. pellet over which is placed a felt washer. A central perforation in the pellet accommodates a No. 63 detonator with a felt disc inserted between it and the bottom of the primer tube.

The fuze is all-ways acting. The striker rests on a creep spring inside a striker sleeve. There is a hole in the base of the sleeve through which the striker protrudes when the spring is compressed. The striker head is cut to receive a lead ball. The closing cap is snapped so that a convex surface fits over the ball. A safety pin passes through a hole in the fuze holder and beneath the striker head to rest on the top of the striker sleeve. A length of tape is attached to this pin. The tape winds around the striker holder and has a small lead weight on its free end. A light bazeite cap threads over the whole assembly. This cap is held securely by a piece of adhesive tape.

The grenade is issued with the bag empty and the charge of plastic explosive is inserted through the bottom of the bag under local arrangements.

Operation

First the grenade is primed and the plastic explosive inserted. The adhesive tape is then removed and the safety cap unscrewed in 1/2 of a turn. After the cap is removed the tape must be held in place by the forefinger and thumb. When thrown, the weight on the end of the tape causes the tape to unwind and pull out the safety pin. Only the creep spring is now holding the striker away from the primer cap. On impact the striker is forced into the primer cap, igniting the delay which initiates the detonator and explodes the grenade.

BRITISH

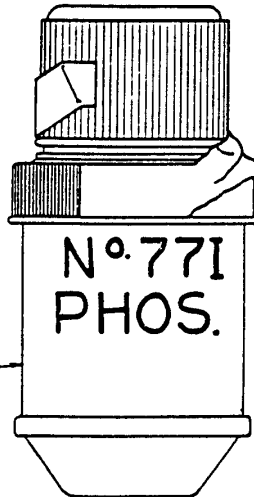
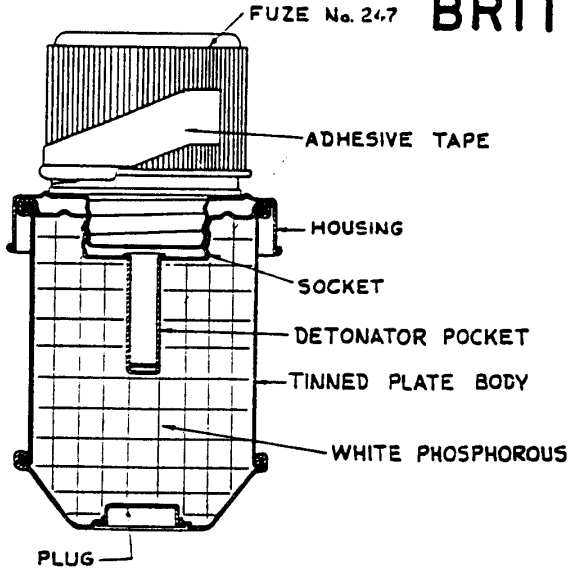

SMOKE GRENADE (W.P.)

NO. 77 MK. I

R E S T R I C T E D

R E S T R I C T E D

Data

Overall length . . . 4.65 in.
Maximum diameter . . . 2.3 in.
Color Green.
Markings Stencilled in
white as shown on
figure.
Total weight 13.5 oz.
Filling White phosphorus.
Fuze No. 247 Mk I.

BRITISH

SMOKE GRENADE

(W.P)

NO. 77 MK. I

Description

The tin plate body is cylindrical in shape except near the base where it is coned. The coned portion has a flat base in which the filling hole is formed. The hole is closed by a soldered lid. The tin plate closing arrangement at the head end of the body includes a socket with a central pocket for the detonator. The socket has a screw thread formed in it to receive the nousing for the attachment of the fuze. The tin plate nousing serves as an adapter for the attachment of the fuze to the body and is in the form of a cap with a knurled periphery and a socket. The socket has a central hole and is screw threaded to engage with the socket in the body.

The fuze is always acting. The striker rests on a creep spring inside a striker sleeve. There is a hole in the base of the sleeve through which the striker protrudes when the spring is compressed. The striker head is cut to receive a lead ball. The closing cap is snapped so that a convex surface fits over the ball. A safety pin passes through a hole in the fuze holder and beneath the striker head to rest on the top of the striker sleeve. A length of tape is attached to the pin. The tape winds around the striker holder and has a small lead weight on its free end. A light bakelite cap threads over this whole assembly. This cap is held securely by a piece of adhesive tape.

Operation

The nousing, together with the fuze, is removed by unscrewing the nousing, and the detonator is inserted in the pocket with the open end towards the fuze.

The adhesive tape is then removed and the safety cap unscrewed in 1/2 of a turn. After the cap is removed the tape must be held in place by the forefinger and thumb. When thrown, the weight on the end of the tape causes the tape to unwind and pull out the safety pin. Only the creep spring is now holding the striker away from the primer cap. On impact the striker is forced into the primer cap, igniting the relay which initiates the detonator and explodes the grenade, scattering the white phosphorus. The white phosphorus ignites spontaneously causing a heavy white smoke screen, and the small fragments are of an incendiary nature.

BRITISH

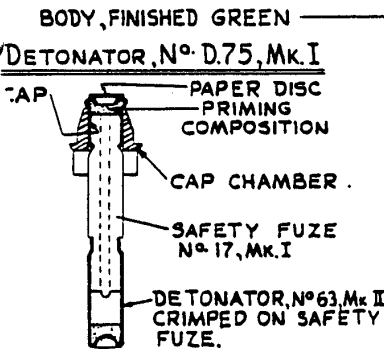
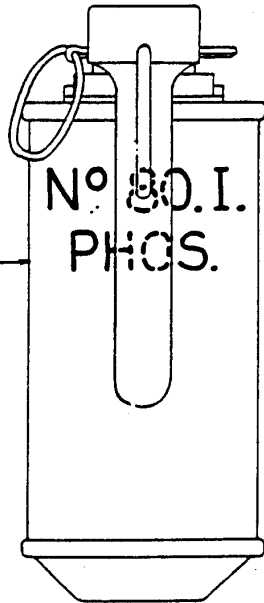
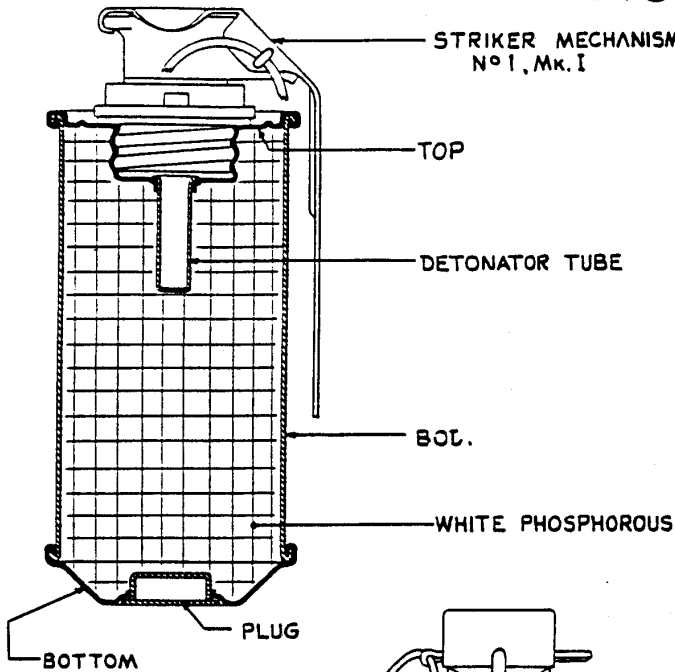

SMOKE GRENADE (W.P) NO. 80 MK. I

BRITISH

122

R E S T R I C T E D

Data

Overall length . . . 5.5 in.
Maximum diameter . . . 2.4 in.
Color Green.
Markings In black - see
drawing.
Total weight 13 oz.
Filling White phosphorus.
Delay 2 $\frac{1}{4}$ - 4 seconds.

BRITISH

**SMOKE
GRENADE (W.P.)**

NO. 80 MK.I

Description

The empty components of this smoke grenade comprise a cylindrical body, top, detonator tube, bottom with filling hole, and a filling whole plug. All are of tinplate except the detonator tube which is of brass. The top is secured to one end of the body by a folded joint, the joint being soldered. A threaded recess in the top accommodates the striker mechanism adapter and also carries the detonator tube which is secured to it by soldering. A charge of white phosphorus is contained in the body and retained by a bottom plate folded over onto the body, the joint being soldered. A filling hole in the bottom is closed by a soldered-in plug. The detonator is of sufficient strength to burst the grenade and scatter the W.P.

The striker mechanism comprises a zinc base alloy-mazak housing which carries the striker, striker axis pin, and striker spring. It is suitably shaped to accommodate the safety lever which is retained by a safety pin passed through corresponding holes in the lever and housing. The pin is provided with a ring to facilitate withdrawal.

Operation

The safety pin is removed, care being taken to hold the safety lever firmly in position. The grenade is then thrown. During flight the striker spring causes the striker to rotate about its axis, throw off the safety lever, and strike the percussion cap. The grenade bursts in 2 $\frac{1}{4}$ to 4 seconds.

BRITISH

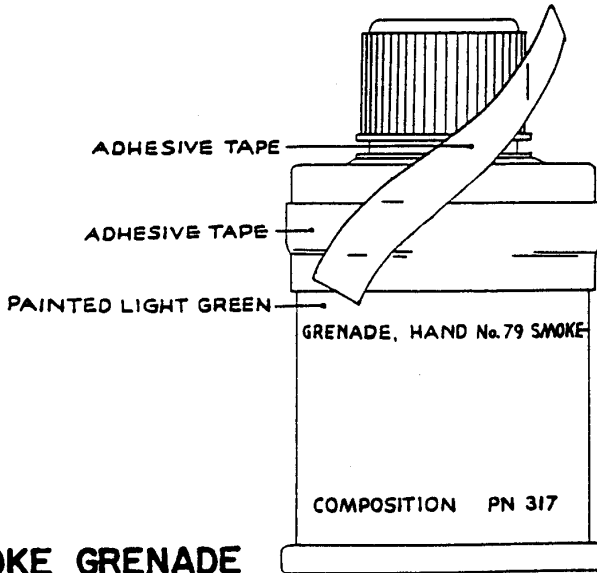
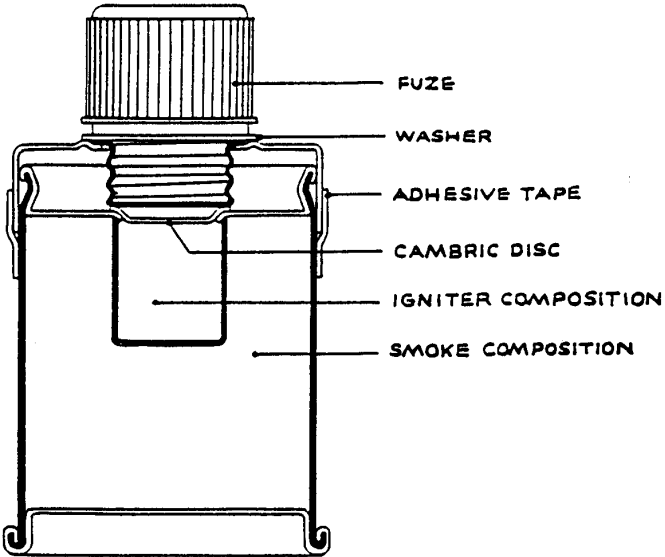

SMOKE GRENADE

NO. 79 MK.I

1-2-3-4-5-6-7-8-9-0

R E S T R I C T E D

BRITISH

SMOKE

GRENADE

NO. 79 MK. I

Data

Overall length . . . 7-2/3 in.
Maximum diameter . . . 4 in.
Color Light green.
Markings In black stencil
as on drawing.
Total weight 1-3/4 lbs. or 1 lb.
6 oz. depending up-
on filling.
Filling Smoke mixture.
Fuze No. 247 Mk I.

Description

This grenade has a cylindrical tin plate body, the lid being soldered in one or two places to the body and further secured by adhesive tape. The body is closed by a disc, pressed in and fitted with a container for the igniter while the lid carries a threaded socket for the fuze holder.

The grenade is filled with the P.N. 317, P.N. 411, P.N. 83, or P.N. 83M smoke mixture and the igniter container with P.N. 227 composition. A gunpowder primed cambric disc is fitted above the container to pick up the flash from the fuze and ignite the P.N. 227.

The fuze is all-ways acting. The striker rests on a creep spring inside a striker sleeve. There is a hole in the base of the sleeve through which the striker protrudes when the spring is compressed. The striker head is cut to receive a lead ball. The closing cap is shaped so that a convex surface fits over the ball. A safety pin passes through a hole in the fuze holder and beneath the striker head to rest on the top of the striker sleeve. A length of tape is attached to this pin. The tape winds around the striker holder and has a small lead weight on its free end. A light bakelite cap threads over the whole assembly. This cap is held securely by a piece of adhesive tape.

Operation

The adhesive tape and the fuze cap are removed. When the grenade is thrown the tape unwinds and withdraws the safety pin. Only the creep spring is then holding the striker away from the primer cap. On impact, the striker is forced against the cap. Smoke emission commences about 5 seconds later and continues for from 40 to 60 seconds.

BRITISH

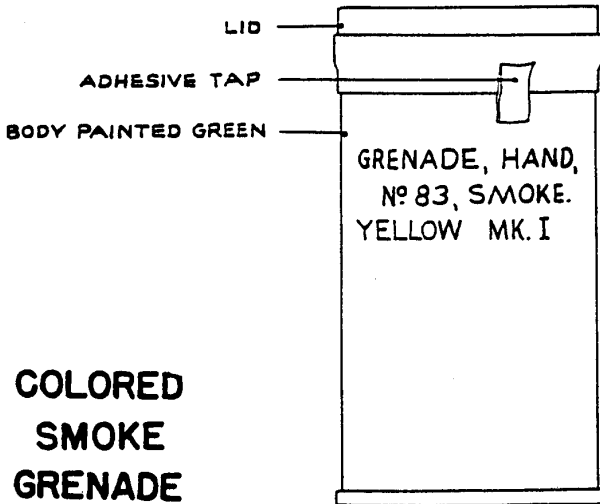
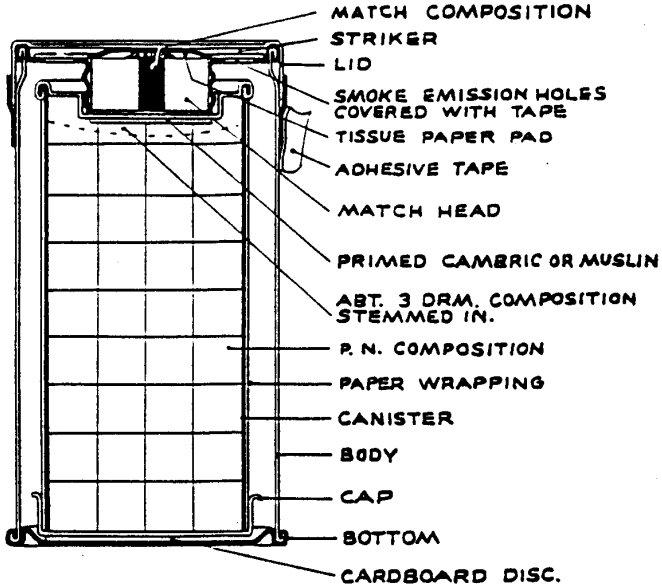

**COLORED
SMOKE
GRENADE
NO. 83 MK. I**

R E S T R I C T E D

Data

Overall length . . . 4.45 in.
Maximum diameter . . . 2.55 in.
Color Green.
Markings In black - see
drawing.
Filling PW Smoke Mixture
Delay 4 seconds.

BRITISH
COLORED SMOKE
GRENADE
NO. 83 MK. I

Description

This smoke grenade is cylindrical in shape and contains a perforated canister filled with blue, green, red, or yellow smoke composition. The igniting arrangements are carried in the head. The grenade body is of tin plate, all other empty components are of blackplate.

A flanged top is secured to one end of the body by a folded joint, the top being recessed to accommodate the match head. Four equispaced smoke emission holes are prepared around the top and sealed by shellacked adhesive tape. Match composition P.N. 196 is filled into the nose of a cylindrical cork match head, the composition being built up on the outside to give a good striking medium. A striker, in the form of a strawboard washer primed with striker composition P.N. 288 on one half of one side, is carried in the top of the body, primed side uppermost.

The canister body with its perforations covered by a wrapping of paper coated with glue or other adhesive is fitted at one end with a flanged top folded over on to the body. The top is shaped to seat the recessed top of the grenade body containing the match head and has a 1 inch square, or disc, of primed cambric or muslin shellacked to its underside with the primed surface adjacent to about 3 drams of composition stemmed in the neck of the canister. The canister is closed by a cap and retained in the grenade body by a bottom plate.

A lid fits over the body for transit purposes. The junction of the lid and body is sealed with a strip of adhesive tape formed with a tag to facilitate removal. To prevent accidental functioning of the match composition a pad of tissue paper is interposed between lid and igniter.

Operation

First remove the lid and striker. Then the striker must be drawn sharply across the match composition. Smoke is emitted about four seconds after ignition and continues for 20 - 40 seconds.

BRITISH

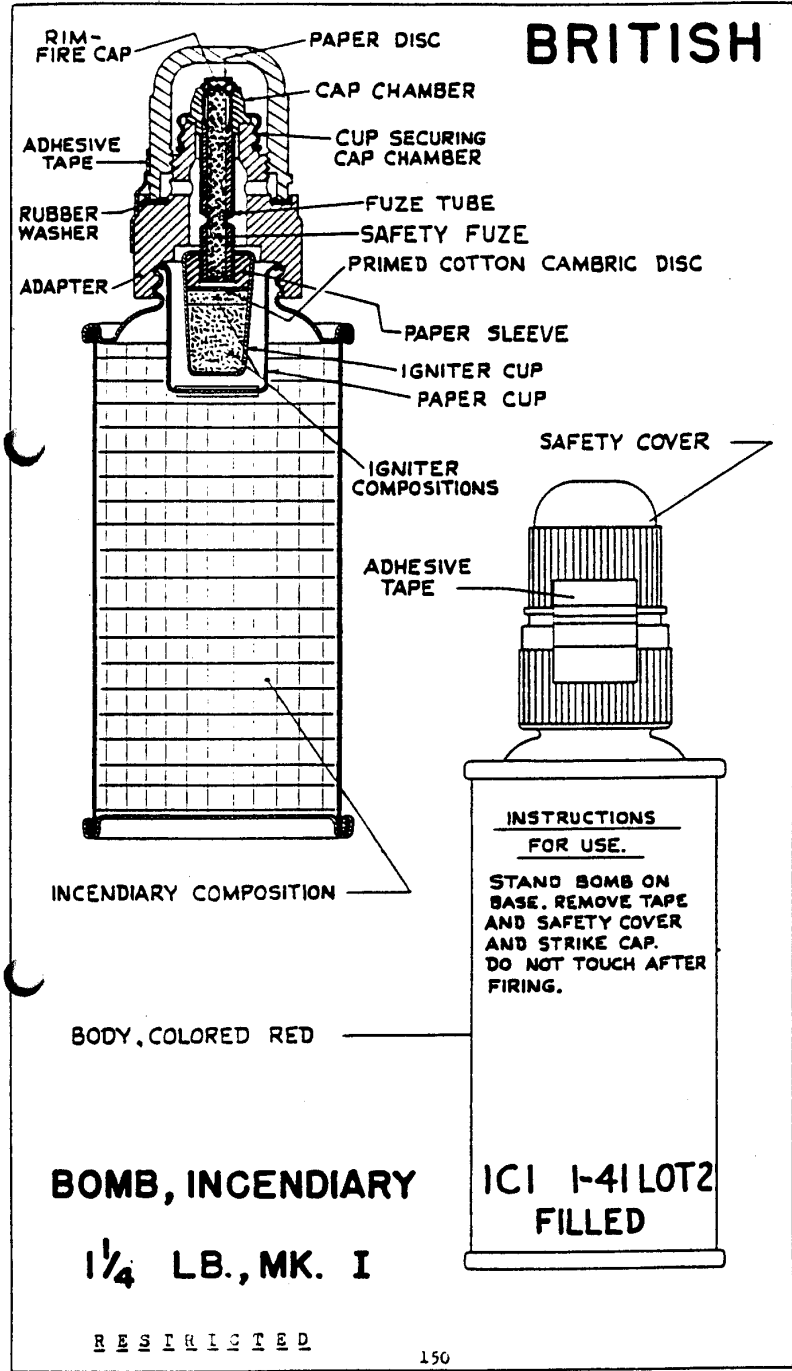

BOMB, INCENDIARY

1 1/4 LB., MK. I

RESTRICTED

BRITISH

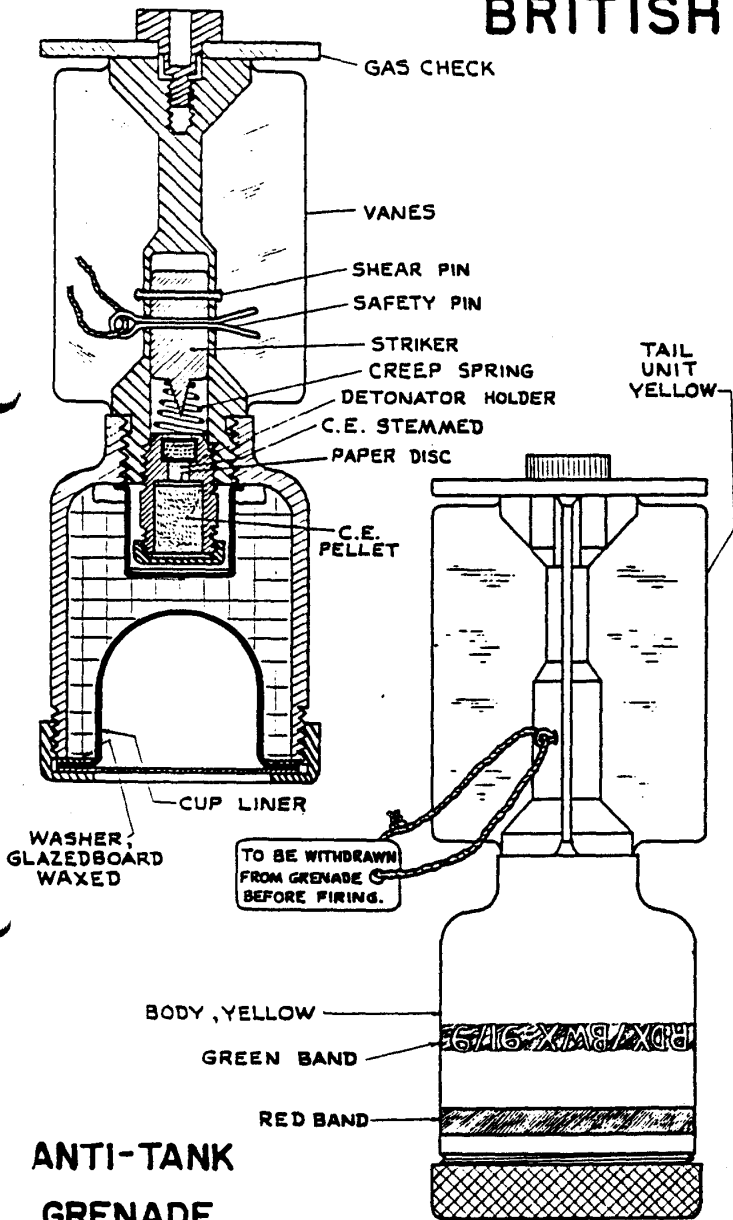

ANTI-TANK GRENADE

NO. 68

R E F E R T O T H E

BRITISH

BRITISH

Data

Overall length . . . 7 in.
Diameter 2.5 in.
Type filling RDX/B.W.X., P.E.,
or Lyddite.
Weight of filling. . 5.5 oz.
Total weight 1.95 lbs.
Markings Painted buff col-
or with red filling band
around top; green band
around center of body is
stencilled to indicate
type of filling. The ser-
ial No.68 A.T. is sten-
cilled on the tail fin.

ANTI-TANK
GRENADE
NO. 68

Description

The grenade consists of a steel bell-shaped body fitted with a tail. The open end of the body is fitted with a thin metal cup which forms a hollow in the H.E. The cup is secured by a screw collar. The dome of the body is bored to carry the detonator holder and threaded to receive the tail section. The tail has four straight vanes and is centrally recessed to receive the striker. A copper shear wire and safety pin secure the striker in position, the pin being removed before grenade is fired. The gas check plates are secured either by metal rivets or in an integral casting with the fins of the grenade.

Operation

Before firing the grenade from the discharger, the safety pin must be removed. The striker is located slightly away from the rear of the slot containing it. On setback, the striker moves to the rear, shearing the shear wire. It is then held only by the creep spring. On impact the striker overcomes the creep spring and hits the detonator to explode the grenade. The effective range is given to be from 50 to 75 yards.

Remarks

There are four Marks of this grenade. Mark I and II are obsolete, and Mark III and IV are identical with the exception of the detonator holder which is slightly modified in the Mark IV design. Special discharge cups for .30 rifles are used with .30 grenade cartridges.

BRITISH

ANTI-TANK S.T. GRENADE NO. 74 MK.II

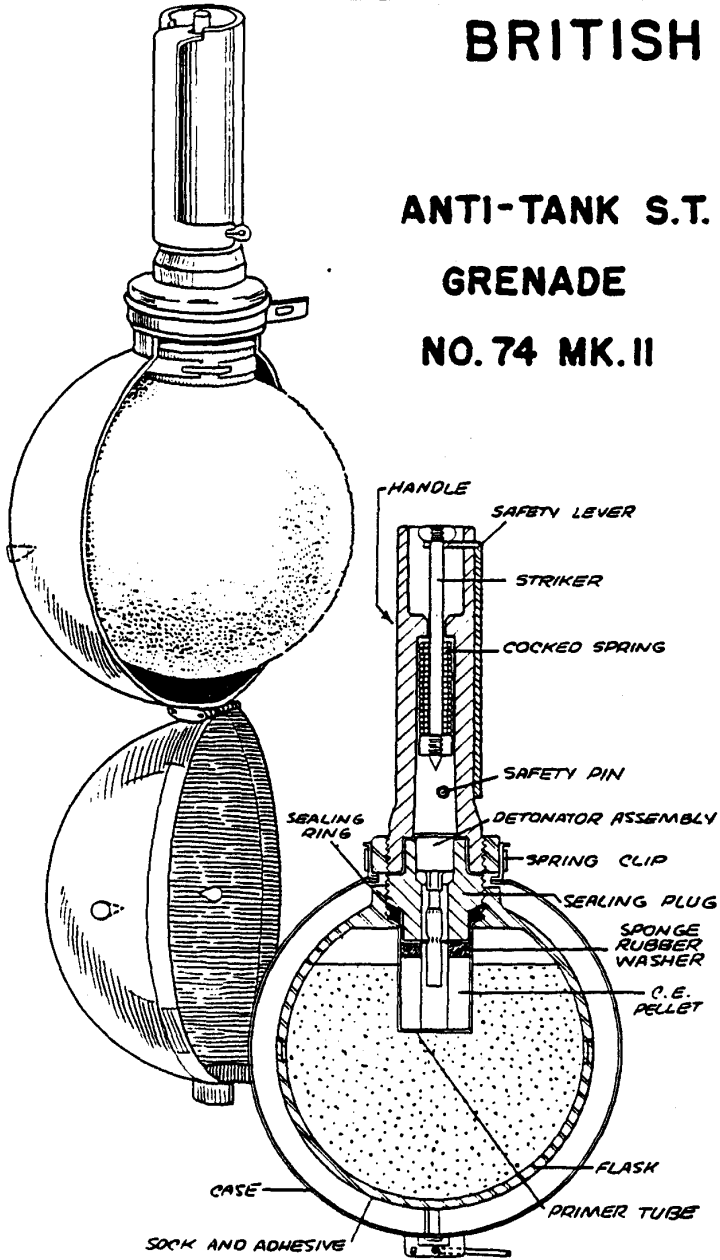

R E S T R I C T E D

Data

Overall length . . . 9 in.
Maximum diameter . . . 4-1/2 in.
Color Body brown;
 handle black.
Total weight 2-1/4 lbs.
Filling Incendiary, No-
 bels #823.
Delay 5 seconds.

BRITISH

ANTI-TANK S.T.

GRENADE

NO. 74 MK. II

Description

This grenade consists of a globular bakelite flask containing the incendiary filling, which is primarily nitro-glycerine and nitro-cellulose, a bakelite handle containing the firing mechanism, and an adhesive treated sock. The sock covers the flask and is very sticky. The handle attaches to the flask by means of a bakelite locking ring. Within the handle is a striker and a striker spring. A safety lever fits under the head of the striker and down the handle to hold the striker up and the spring compressed. A safety pin passes through holes in projections on the safety lever, through the handle, and under the striker. The flask is closed at the neck by an aluminum container into which the detonator assembly is inserted immediately before use. The detonator assembly consists of a percussion cap, a 5-second delay, a detonator and a C.E. pellet.

A light metal container made in two hemispherical sections clamps over the sticky flask in handling and shipping. This must be removed before the grenade is used.

Operation

The detonator assembly is placed, pellet first, into the well in the flask. The handle is then secured to the neck of the grenade by the locking ring. The handle must be grasped firmly with the hand over the safety lever before the safety pin is withdrawn. After the safety pin is removed, when the handle is released the striker spring will force the striker down, throwing off the safety lever and striking the percussion cap.

This grenade has been designed for use against A.F.V.'s. It is designed to stick to the target. The grenade will not stick on a sloping surface should it be wet, muddy, or oily. Although it can be thrown for short distances, far better effect will be obtained if the grenade is placed.

The viscose explosive filling tends to run at moderate temperatures, thus storage temperatures must be kept low. The grenades are definitely subject to sympathetic detonation.

NOTE: The Mark I grenade has a flask made of glass.

BRITISH

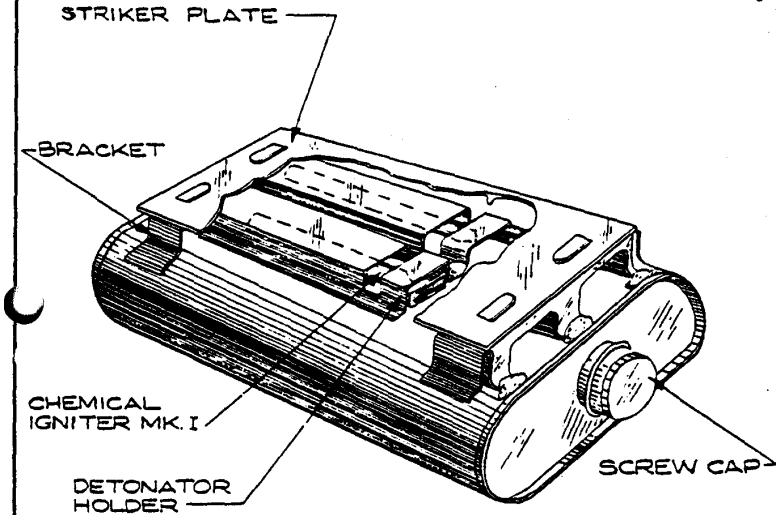

GRENADE

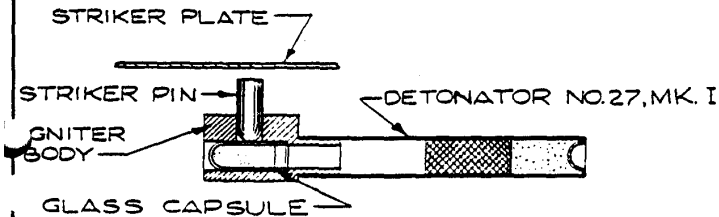

IGNITER, SPECIAL, NO. 1, MK. I

ANTI-TANK "HAWKINS" GRENADE NO. 75

R E S T R I C T E D

BRITISH

ANTI-TANK

"HAWKINS"

GRENADE

NO. 75

Data
Overfall length . . . 7 in.
Maximum width . . . 3-11/16 in.
Color . . . Buff.
Markings . . . No. 75, Monogram
of Mfg., date of filling,
lot number, stamped on body.
When filled, red ring
around cap. Type of filling
stencilled in black on base.
With filling 1 below "No-
bels 704B & 4 exploders" is
stencilled on the base.

Total weight . . . 2-1/4 lbs.

Filling . . . 1) Nobels 704B &
4 exploders.

2) Military ammonal & 4 exploders.

3) Burrowite and 4 exploders.

Fuze . . . Pressure device.

Description

This grenade consists of a 1 pint capacity flat tin plate can, rectangular in shape with rounded corners. It is filled through a hole in the end over which a tin cap is screwed and cemented to provide water tightness. On one side of the can are two metal pockets with slots cut in them, which form the detonator holders. These pockets have easily bandable metal tabs to close them. The striker plate is supported above the detonator holders by two brackets, one on each end of the can. The striker plate is a light metal plate with two strikers attached to its underside. It is secured to the brackets by two bend tabs so that the strikers are immediately over the slots in the detonator holders.

The detonator unit consists of an igniter and detonator, and two of these units are used with each grenade. The igniter can be distinguished as a tin plate tube closed at one end by flattening, and it is painted red. A rubber tube is rolled on to the igniter. The detonator is an aluminum tube open at one end and smaller in diameter than the igniter.

The grenade is so shaped that when thrown it will come to rest with the striker plate either on top or underneath. It will operate equally well in either position.

Operation .

Insert the open end of the detonator into the open end of the igniter. Then unroll the rubber tube on the igniter to cover the joint. This provides a water tight seal. Insert a detonator assembly, detonator end first, into each of the pockets of the detonator holder through the hole in the striker plate bracket. Bend over the metal tabs, thus securing the detonator assemblies in the pockets. The red painted portions of the assemblies should now be visible in the slots of the detonator holders. The grenade is designed for use against A.F.V.'s to break their tracks and damage their suspension. The grenade is thrown or placed so that it will be run over. The pressure of the vehicle upon the striker plate will force the strikers through the slots in the detonator holders, crush the igniter tubes and break the glass capsules containing sulphuric acid. The action of the acid on the potassium chlorate and charcoal produces an immediate flash which sets off the detonators and explodes the grenade.

Remarks

The #75A grenade is distinguishable from the #75 by the letter "A" stencilled on the side of it. It has the ammonal filling and is only 80% as powerful as the #75.

The mark is a variation of the mark in is shown as follows:

1. The number 1 is in the line with the letter 'A'.
2. The letter 'A' is in the line with the number 1.